

SHAPING A SUSTAINABLE FUTURE THROUGH POWDER METALLURGY INNOVATION



TABLE OF CONTENT

4

GKN
POWDER
METALLURGY

6

POWDER
METALLURGY
AT A GLANCE

8

WHY POWDER
METALLURGY
MATTERS

18

LEADING THE
INDUSTRY –
OUR SUCCESS
FACTORS

19

GLOBAL
SCALE

20

MASTERING
TECHNOLOGIES

Conventional Powder Metallurgy (PM)	21
Metal Injection Molding (MIM).....	21
Metal Additive Manufacturing (AM)	22
Forged Powder Metallurgy (FPM)	22
Lightweight Aluminum PM.....	23
Porous Metal Technology	23

9

OUR PURPOSE & VALUES

10

WHAT WE DO

Global Leader in Metal Powders.....	10
Powders & Materials.....	11
Additives	11
Press-Ready Premixes	11
Advanced Materials for Electrification	11

12

PARTS & COMPONENTS

Drivetrain & E-Mobility Components	13
Thermal & Fluid Management.....	14
Lightweight Aluminum Solutions	15
Battery Solutions.....	16
Filters & Porous Media.....	16

24

INNOVATION

26

SUSTAINABILITY

27

OUR LEGACY

GKN POWDER METALLURGY

GKN Powder Metallurgy is a global leader in powder-metal solutions, combining deep technical expertise, cutting-edge technologies, and a global presence to deliver innovative, high-performance components across automotive, industrial, and other demanding sectors.

With more than 5,000 specialists across 28 manufacturing facilities in 9 countries, we offer scalable, that ensure consistency, speed, and reliability, wherever our customers operate. Our global footprint is supported by an integrated network of R&D centers and engineering hubs that connect customers to the forefront of powder metallurgy.

Building on 260 years of engineering heritage, GKN covers the entire value chain, from metal powders to the precision parts they become. Our end-to-end capability, from design to high-volume production, allows us to set industry benchmarks for performance, efficiency, and sustainability in powder metallurgy.

Global operations close to our customers





POWDER METALLURGY AT A GLANCE



Powder metallurgy (PM) is an advanced manufacturing process that transforms metal powders into high-performance components. It involves blending and compacting metal powders in a die under high pressure to form a “green” part, which is then sintered, heated in a furnace at a temperature below the metal’s melting point. This causes the particles to fuse into a solid, dense, and durable component with a fine, uniform microstructure.

PM is particularly suited for high-volume production of small or complex shapes that would be challenging or wasteful to produce using traditional casting or machining methods. From gears and bearings to parts for electronic components and medical devices, powder metallurgy efficiently delivers consistent quality, minimal waste, and reduced need for post-processing.

PM encompasses multiple technologies and processes designed for different applications. We deploy the full spectrum of powder technologies, each chosen according to part size, complexity, and performance targets:

PM TECHNOLOGIES

- **Conventional Press and Sinter**
High volume compaction followed by continuous sintering.
- **Metal Injection Molding (MIM)**
Fine powders and polymer binders injected to create miniature or highly intricate shapes.
- **Metal Additive Manufacturing (AM)**
Laser powder bed fusion and binder jetting for lattice structures, rapid iterations, and functional integration.
- **Forged Powder Metallurgy (FPM)**
Pre forms hot forged after sintering to reach wrought like density and exceptional fatigue strength.
- **Aluminum/ Copper Powder Metallurgy**
Proprietary high conductivity and high strength Al alloys and metal matrix composites for lightweight drivetrain parts.
- **Porous Metal Technology**
Controlled porosity for self lubricating bearings, acoustic damping, and filtration or fuel cell diffusion layers.
- **Metal Matrix Composites**
Powder Metallurgy (PM) offers a broad range of Metal Matrix Composite (MMC) materials which combine metallic, non-metallic and ceramic properties to a unique property spectrum. Friction linings, brake pads, high-thermal conductive materials as well as low-thermal expansion materials can be designed individually.

WHY POWDER METALLURGY MATTERS

At GKN Powder Metallurgy, we see powder metallurgy (PM) as more than a process. It is a foundation for sustainable innovation across the automotive and industrial landscape. By compacting and sintering metal powders, PM converts over 97% of material into finished parts, minimizing waste, energy use, and cost. This supports our mission: to enable innovation in a sustainable way: smarter designs, lighter vehicles, and measurable environmental impact.

EFFICIENCY & SUSTAINABILITY

PM is a recognized green technology that supports the circular economy. We use up to 100% recycled scrap metal to produce our powders, reducing raw material use and emissions. Our streamlined processes cut energy consumption and help customers meet their sustainability goals.

DESIGN WITHOUT LIMITS

PM unlocks unique design flexibility. Complex shapes, internal features, and multi-material zones are achievable in one repeatable step. The result: high-strength, durable components tailored for demanding applications, from self-lubricating bearings to advanced filtration systems.

ACCELERATING INNOVATION

Electrification demands performance without compromise. Our powder-based components enable lightweight structures and efficient thermal management, core technologies already used in millions of EVs worldwide. With our Porous Metal Technology, we place engineered porosity exactly where it's needed, combining strength, flow control, and durability in a single structure. Together, these innovations drive lighter, more efficient, and more reliable systems for the next generation of mobility.

SCALABLE & COST-EFFECTIVE

From prototyping to high-volume production, PM delivers repeatable quality with speed and efficiency.

Our global footprint and local supply chains ensure flexible, cost-effective delivery, wherever our customers operate.

OUR PURPOSE & VALUES

At GKN Powder Metallurgy, our purpose is simple: we shape a sustainable future with powder metal innovation. We use our deep technical expertise and passion for solving real-world challenges to drive progress for our customers, communities, and the planet.

We **WIN** by working **TOGETHER** to create **INNOVATIVE** solutions in a **SUSTAINABLE** way, while our **LEGACY** makes us resilient.



WIN – we set ambitious goals and relentlessly pursue excellence, overcoming challenges to deliver market-leading solutions for our customers.



TOGETHER – we collaborate across functions, geographies, and with our partners to harness diverse skills and perspectives, achieving more as one global team.



INNOVATIVE – we embrace curiosity and experimentation, continually pushing boundaries with new ideas, processes, and technologies.



SUSTAINABLE – we commit to environmental stewardship and social responsibility, embedding sustainability into every step of our product lifecycle.



LEGACY – we draw on over 260 years of metal-working expertise, honoring our heritage while adapting with agility to tomorrow's challenges.

WHAT WE DO

We deliver end-to-end solutions through two core capabilities: metal powder production and precision component manufacturing. This integrated model allows us to support customers from raw material development through to finished parts, ensuring consistency, scalability, and performance across every stage of production.

GLOBAL LEADER IN METAL POWDERS

As the global leader in atomized metal powders, we produce over 250,000 tons annually for use in conventional press-and-sinter powder metallurgy (PM), additive manufacturing, and forged PM applications. Our powders are engineered to meet the demanding standards of automotive, industrial, medical, and energy sectors, offering reliable performance, purity, and consistency at scale. We employ three key atomization technologies to meet diverse application needs:

- > **Water atomization** creates irregular particles suited for structural components in the most cost-effective manner.
- > **Gas atomization** produces spherical powders with excellent flow characteristics, ideal for additive manufacturing and precision applications.
- > **EIGA (Electrode Induction Gas Atomization)** a contactless process used to produce ultra-clean powders for high-purity applications.

After atomization, powders can be annealed, sieved, blended, and lubricated to create ready-to-press premixes with optimized flow and apparent density. Our vertically integrated production ensures full traceability, tight quality control, and a stable global supply chain.

POWDERS & MATERIALS

Our comprehensive portfolio includes pure iron and a wide range of ferrous alloys, as well as an array of other custom materials available upon request. Each powder lot undergoes rigorous quality control to ensure precise chemistry, consistent particle size, and optimal powder properties. Engineered to deliver exceptional performance, our powders are tailored for demanding applications, from high-volume automotive and industrial components to precision medical and aerospace parts.

ADDITIVES

GKN specializes in creating high-performance additives that fine-tune material properties for specialized requirements. By adding precise amounts of alloying elements, lubricants, and performance enhancing additives, we enable our customers to optimize their production processes from start-to-finish. Our additives can be used to improve powder flow and consistency, enhance compaction density, promote uniformity in sintering, boost machinability and significantly increase finished part performance, helping achieve target specifications and throughput.

PRESS-READY PREMIXES

Our press-ready premixes are carefully pre-blended combinations of base powders, additives, and proprietary lubricants, meticulously formulated to streamline pressing and sintering operations. With press-ready mixes, we simplify your manufacturing by eliminating in-house mixing steps, reducing handling and segregation errors, and ensuring perfect repeatability batch-after-batch. These precision blends can be further optimized through use of binder treatment, ensuring consistent part-to-part results, higher productivity, and lower overall manufacturing costs.

ADVANCED MATERIALS FOR ELECTRIFICATION

In addition to powders for structural applications, we continue to develop advanced materials for electrification applications including precursors for batteries, high surface area materials for chemical applications and energy storage. These materials support the global transition toward electrification and sustainable energy. Together, these powder solutions provide the input materials for virtually every powder metallurgy process and form the backbone of high-quality PM components. We work directly with our customers to create custom material solutions while maintaining strict quality standards and scalable production to support our customers' material needs and supply chains worldwide.

PARTS & COMPONENTS

Through our parts business, we manufacture precision metal components for automotive, industrial, and other high-performance applications. An industry-leading 10 million parts leave our factories every day. Using processes like sintering, MIM, and metal 3D printing, we produce custom components to exact specifications, engineered for strength, durability, and optimal weight. We collaborate with our customers from design to production, optimizing each part for performance and efficiency. From e-mobility components to thermal, and porous solutions, GKN delivers at scale, powering innovation across industries.



DRIVETRAIN & E-MOBILITY COMPONENTS

We manufacture high-precision drivetrain parts that power everything from traditional transmissions to cutting-edge electric drives. Our latest PM technology allows us to produce gears, clutches, and actuator components that maximize efficiency and strength while minimizing weight. The result is smoother power delivery, quieter operation, and robust reliability for critical powertrain systems in both conventional and electrified vehicles.

> Precision Gears & Differentials

Sintered steel gearsets and differential components deliver smooth, quiet power with minimal friction. Advanced designs reduce noise and vibration in electric drivetrains and enable lighter, more compact transmissions without sacrificing strength.

> Clutch & Synchronizer Hubs

Wear-resistant clutch plates and hubs ensure smooth shifting under high loads. Near-net-shape PM reduces weight and increases durability while extending transmission life and improving efficiency.

> X-by-Wire Components

Precision-engineered powder metal parts enable reliable electromechanical actuation in next-generation vehicle systems. They ensure efficient power transfer, compact design, and proven durability for steer-, brake-, and shift-by-wire applications.

> Parking Gears

Superior performance with high strength and precision. Designed with a lightweight net-shape construction, they ensure consistent material quality while minimizing additional machining processes, such as broaching. With standard heat treatment conditions and optimized manufacturing efficiency, these gears provide a cost-effective solution for reliable performance.

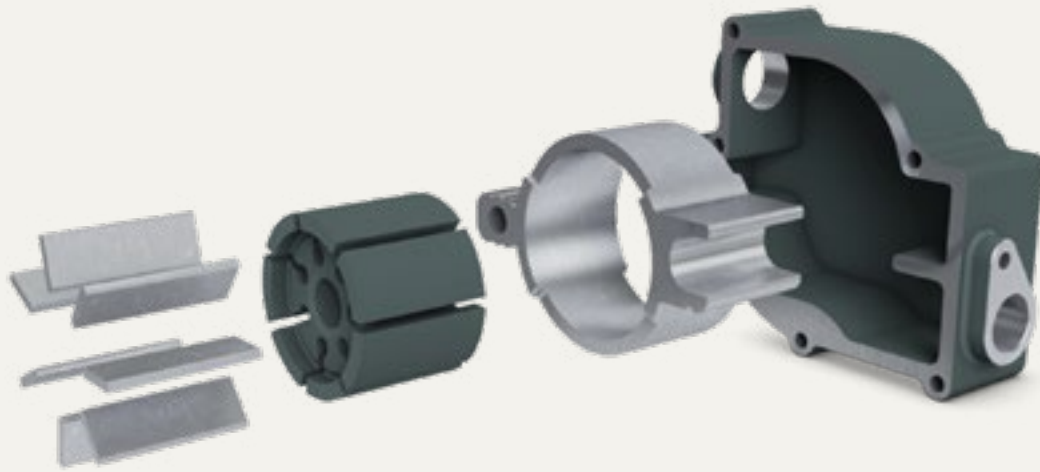

THERMAL & FLUID MANAGEMENT

Controlling heat and fluid flow is essential to modern powertrains, especially in efficient EVs. GKN's thermal and fluid management parts keep batteries, motors, and engines at peak performance. Using advanced materials like high-conductivity aluminum, we design pump components, heat

exchangers, and fluid system parts that dissipate heat faster, ensure reliable lubrication/cooling, and integrate easily into compact assemblies. The result: enhanced vehicle range, longevity, and operational efficiency under all conditions.

RANGE

> Pump Gears & Rotors

Precision oil and coolant pump components ensure consistent flow with minimal energy loss. Our sintered gears run quietly and reliably, maintaining lubrication and cooling to boost engine and EV efficiency.

> Heat Sinks & Cooling Plates

Made from high-conductivity materials (aluminium and copper), these lightweight components draw heat from batteries and power electronics, doubling the thermal performance of cast parts and improving charging speed and longevity.





LIGHTWEIGHT ALUMINUM SOLUTIONS

Our structural solutions use innovative lightweight metals to replace heavier steel parts without compromising strength. GKN's proprietary aluminum powder formulations yield high-strength components that dramatically cut weight, in some cases up to 60% lighter than traditional steel. From structural brackets to carrier frames, we engineer each part for optimal stiffness, crash safety, and integration. Lighter vehicles mean better fuel economy, increased EV range, and lower emissions, all achieved with parts that meet or exceed industry standards.



RANGE

> **Camshaft Caps**

Net-shape PM aluminum caps mount the camshaft with extreme dimensional accuracy while trimming mass in overhead-cam engines.

> **Planetary Carriers**

Our PM carriers for e- and hybrid gearsets achieve a 50% weight reduction and lower rotating inertia, directly improving drivetrain efficiency and range.

> **High-Thermal-Conductivity Heat Sinks**

Newly developed PM-aluminum heat-sink designs provide cost-effective, high-conductivity cooling that outperforms cast aluminum, ideal for power electronics.

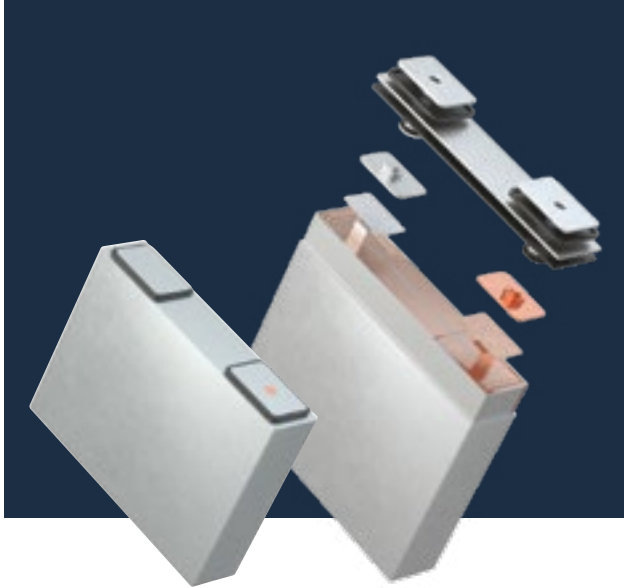

Battery Solutions

GKN Powder Metallurgy produces copper- and aluminum-powder components that create the high-current pathways inside an EV battery pack. Powder metallurgy lets us form complex shapes in one step, giving designers “geometry freedom to produce multi-level battery terminals” and other connecting elements while maintaining the “high-conductivity material” needed for efficient power flow.

RANGE

> Battery Bus Bars & HV Connecting Elements

Custom bus bars link individual cells in the battery pack and connect battery to inverter and various electrical systems, using copper or aluminum for high-voltage applications.

> Battery Terminals/Cell Connectors

Powder-metal terminals connect the anode and cathode of a single cell to the circuits, can be designed as multi-level connectors, and are used in cylindrical and prismatic battery cells.

Filters & Porous Media

Beyond structural components, GKN Powder Metallurgy produces specialized porous metal that solve unique engineering challenges. Our porous PM components use controlled porosity in liquid- and gas-filtration, catalyst recovery, silencing and various other applications where reliable performance in challenging environment is key to success.

RANGE

> Sintered Filters

Designed for precise particle filtration, chemical-, petrochemical-, medical-/ pharmaceutical-processing, exhaust aftertreatment, flame arrestors, and more. Built for durability, they offer excellent corrosion and temperature resistance in aggressive environments.

> Silencers & Flow Restrictors

Compact and reliable, these parts reduce noise and modulate airflow in applications like pneumatics, medical (breathing) systems or high precision semiconductor manufacturing.

> Spargers & Fluidizers

Used to diffuse gas into liquids or aerate bulk solids, these parts provide a high gas conversion rate and laminar flow and are tailored for industries like pharmaceuticals, food processing, and water treatment.

> Our high-efficiency **Porous Transport Layers (PTL)** are crucial in PEM electrolyzers for green hydrogen production, offering low electrical resistance and enhanced durability under corrosive conditions.

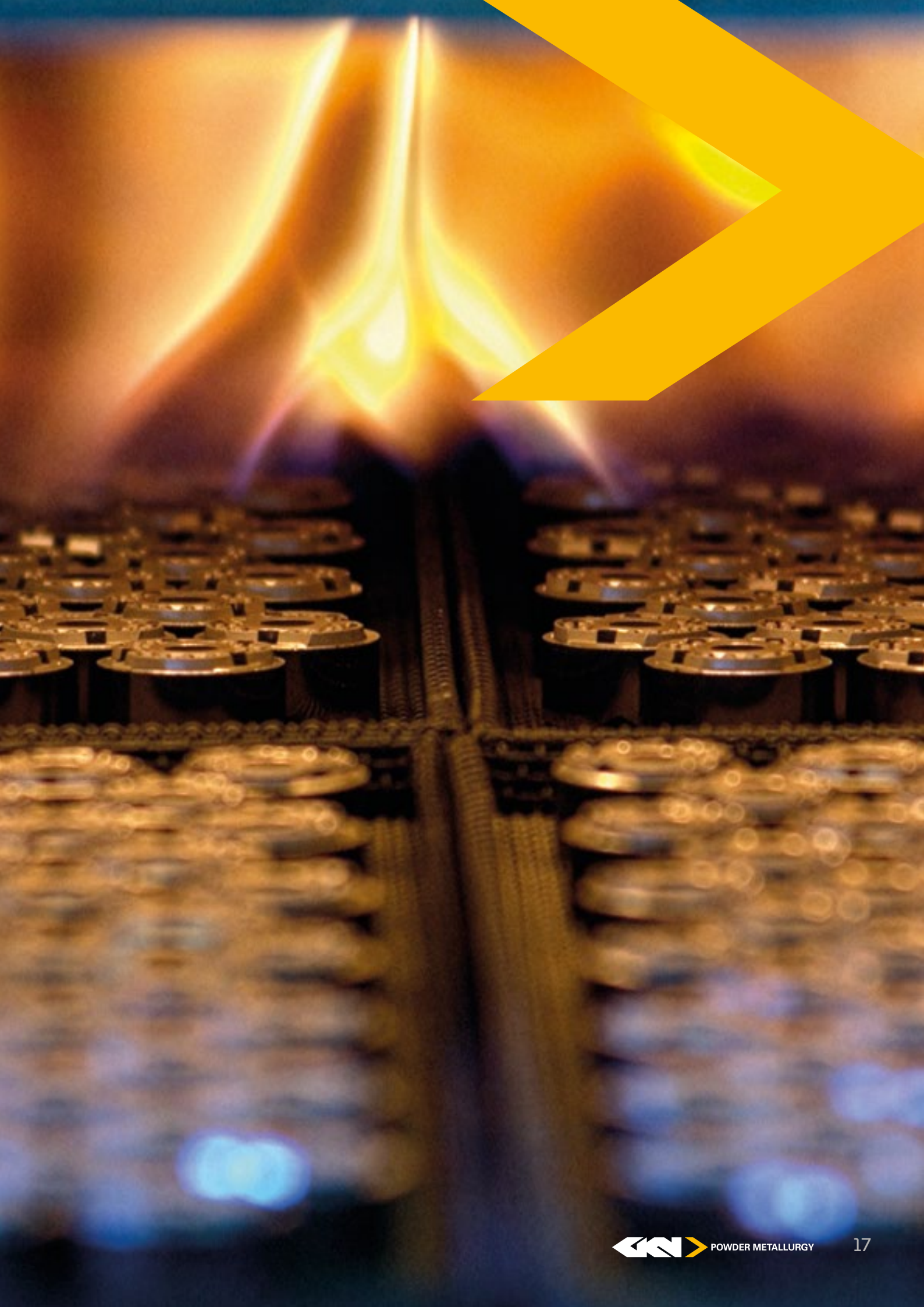

LEADING THE INDUSTRY – OUR SUCCESS FACTORS

We lead the powder metallurgy industry by excelling in the areas that matter most to our partners. Our key success factors include:

Expertise & Quality – decades of know-how and a zero-defect mindset ensure consistent, top-tier solutions.

Innovation Culture – we push boundaries in materials, processes, and design to keep our customers at the cutting edge.

Customer Collaboration – we partner from concept to production to create tailor-made solutions that meet every customer goal.

Global Reach, Local Support – our worldwide network ensures consistent quality, local engineering support, and reliable delivery everywhere our customers operate.

Integrated Offerings – combining powder production and part manufacturing under one roof ensures quality, efficiency, and faster innovation for our customers.

GLOBAL SCALE

GKN Powder Metallurgy operates on a truly global scale, giving us the ability to serve customers wherever they do business. Our worldwide footprint encompasses:



28

manufacturing facilities across

9

countries in Europe, the Americas, and Asia



250,000

tons of metal powder produced per year



10 million

components produced daily for over

3,000

customers worldwide



2

dedicated innovation centers for R&D and customer co-development



5,000+

passionate team members worldwide

MASTERING TECHNOLOGIES

CONVENTIONAL POWDER METALLURGY (PM)

High-volume efficiency.



KEY BENEFITS

- > **Design freedom** – allows engineers to consolidate multiple functions into a single near net shape part, incorporate undercuts, cross holes, and complex surface textures, and even tailor alloy compositions or controlled porosity, all without costly secondary machining or assembly steps.
- > **Cost-effective precision** – produces millions of cost effective parts, with tight tolerances and little to no machining needed.
- > **Minimal waste** – over 97% material utilization in sintering means almost no scrap, saving cost and reducing environmental impact.
- > **High-volume consistency** – standardized processes deliver repeatable quality for large production runs, ensuring dependability at scale.

METAL INJECTION MOLDING (MIM)

Complex geometries, clinic-grade precision.



KEY BENEFITS

- > **Ultra-fine detail** – thin walls below 1 mm, blind holes, and internal cavities formed in a single shot, then sintered to $\geq 97\%$ density for near-wrought strength.
- > **Expansive alloy portfolio** – from corrosion-proof stainless and wear-resistant alloy steels to heat-resistant alloys, our MIM process delivers exactly the material your applications demand.
- > **Volume on your terms** – multiple automated MIM lines scale seamlessly from pilot runs to millions of parts per year with tight $\pm 0.3\%$ dimensional repeatability.
- > **Cross-industry reach** – automotive, medical, aerospace, defense and industrial customers rely on GKN MIM for lightweight, high-precision components.
- > **Cost and sustainability edge** – near-net shapes cut machining by up to 80%, saving material, cycle time, and CO₂ footprint compared with wrought alternatives.

METAL ADDITIVE MANUFACTURING (AM)

Limitless design, faster to market.



KEY BENEFITS

- > **Accelerating Innovation** – rapid prototyping and GKN's digitally connected print network compress development loops from months to days, letting you test, refine, and launch breakthrough designs first.
- > **Design freedom** – manufacture shapes with internal passages, organic lattice frameworks, and optimized topologies that improve performance (e.g. cooling, strength) beyond conventional designs.
- > **Material and weight savings** – builds only what is needed—minimizing waste powder and enabling significant weight reduction (which in turn can improve efficiency, e.g. lighter EV components for greater range).

FORGED POWDER METALLURGY (FPM)

Ultimate strength and durability.



KEY BENEFITS

- > **Stronger parts with less mass** – our components carry the same loads at up to 20% lower weight, thanks to fine-grained microstructures that boost fatigue strength without compromising durability.
- > **Design freedom, no extra machining** – we forge presintered preforms into near-net shapes, so you get complex geometries ready for assembly, no flash, no draft angles and minimal waste.
- > **Reliable, repeatable quality** – a fully dense, uniform grain structure eliminates hidden voids, delivering repeatable heat-treatment response and long fatigue life part after part.
- > **Sustainability built in** – with up to 100% recycled powder and a shorter process chain, you cut material loss, energy use, and CO₂ footprint while still achieving forged-level performance.

LIGHTWEIGHT ALUMINUM PM

Weight savings without compromise.



KEY BENEFITS

- > **Mass reduction** – up to 50–60% lighter than equivalent steel designs, helping meet aggressive weight targets and improve fuel efficiency or EV range.
- > **High performance** – custom aluminum alloys (including metal matrix composites) provide high strength and stiffness at low density, as well as excellent thermal conductivity for heat dissipation needs.
- > **No trade-off in reliability** – powder metallurgy techniques ensure these aluminum parts have a uniform microstructure and can be heat-treated, achieving the durability required for critical applications, all while avoiding the casting porosity or quality issues of some traditional aluminum processes.
- > **Sustainability** – lighter components contribute to lower energy consumption in operation of vehicles or machinery. Plus, our aluminum PM uses recycled material and near-net-shape forming to minimize waste, aligning with our customers' sustainability goals.

POROUS METAL TECHNOLOGY

Precision filtration and flow control.



KEY BENEFITS

- > **Unmatched durability** – rigid sintered metal construction that resists thermal stress and chemical attacks, outlasting many traditional fiber or membrane filters.
- > **Precise porosity control** – engineered pore structures (down to sub-micron levels) achieve the exact filtration rating or flow restriction required, ensuring consistent performance and product quality.
- > **Efficiency & easy maintenance** – the filters' strength allows for backwashing or cleaning and reuse, while their optimized porosity enables high flow rates with low pressure drop. This results in efficient processes and lower maintenance costs for end users.
- > **Versatile applications** – from filtering particles in gases and liquids, to sparging (gas dispersion) and even noise silencing, our porous metal solutions provide a single-component solution that can replace multi-part assemblies, which simplifies systems and improves reliability.

INNOVATION



At GKN Powder Metallurgy, innovation drives everything we do: from how we design materials to how we manufacture at scale. It's how we lead the powder metallurgy industry, and how we help our customers stay ahead.

Our R&D teams in Europe and North America are focused on advancing the future of manufacturing by:

- > **Innovating near-net-shape processes to minimize machining, material waste, and CO₂ emissions in high-volume manufacturing**
- > **Developing next-generation components for electric vehicles, including drivetrain components, lightweight structures, and thermal management solutions**
- > **Digitalizing our global operations with smart, connected systems to improve speed, quality, and flexibility**
- > **Creating sustainable materials, such as low-CO₂ and recycled powders, to support a circular economy**

We believe the best ideas come from collaboration. That's why we work side-by-side with our customers' engineers to co-develop solutions that move from concept to production: faster, more efficiently, and with fewer compromises.

By focusing on electrification, digitalization, and sustainability, we empower our customers to lead in the next era of manufacturing.

SUSTAINABILITY

At GKN Powder Metallurgy, sustainability is central to how we operate, innovate, and grow. Our goal is clear: achieve **net-zero greenhouse gas emissions across our entire value chain by 2050**. This commitment is officially validated by the **Science Based Targets initiative (SBTi)**.

SCOPE 1 AND 2

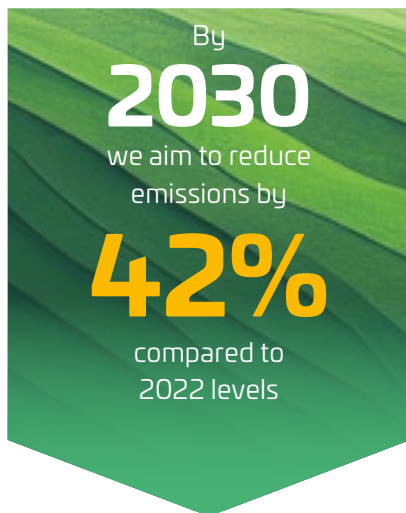

SCOPE 3

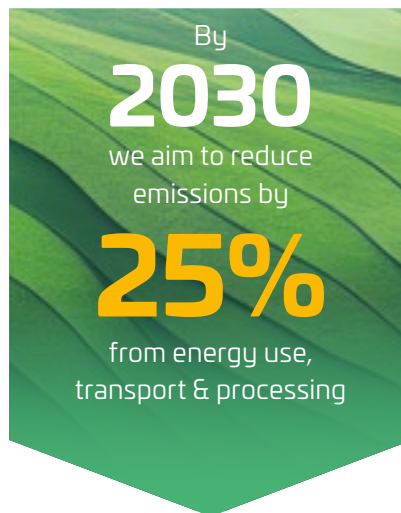

SCOPE 1, 2 AND 3



How we're already making progress:

- > **By 2050 we are committed to reach net zero GHG emissions across entire supply chain**
- > **Over 50% of our electricity is coming from renewable sources**
- > **Our solutions help customers reduce fuel consumptions and CO₂ emissions**

We're also advancing the technologies that make low-carbon manufacturing possible: lightweight parts for electric and hybrid vehicles, thermal and structural systems for batteries, porous solutions for hydrogen applications, and recyclable materials for additive manufacturing.

Sustainability is not a destination. It's a shared journey we're taking with our customers, partners, and teams around the world.



OUR LEGACY

GKN Powder Metallurgy is built on a legacy of innovation, resilience, and engineering excellence. With roots tracing back to 1759, we bring over two and a half centuries of industrial heritage to everything we do.

We were among the early pioneers of powder metallurgy, producing some of the first sintered metal parts for automotive and industrial applications in the early 20th century. Since then, we've grown by continuously pushing the boundaries. We evolved from powdered bearings to today's high-performance, 3D-printed components.

Through decades of economic shifts and technological change, we've remained a trusted partner to the world's leading manufacturers. Many of our customer relationships span generations, a reflection of the quality, consistency, and innovation we deliver.

Our components have quietly powered millions of vehicles, machines, and devices. From the rise of mass-produced cars to the age of electrification and renewable energy, GKN has helped shape the future of manufacturing, one part at a time.

That legacy isn't just history. It gives us the confidence, agility, and expertise to help our partners meet tomorrow's toughest challenges, just as we have done for over 260 years.



GKN POWDER METALLURGY

World leading provider of powder metal solutions



gknpm.com

Contact Information

GKN Powder Metallurgy – Pennefeldsweg 11–15 / 53177 Bonn / Germany